

Japanese Kokai Patent Application No. 2001-338838

Job No.: 530-119840

Ref.: JP2001338838A

Translated from Japanese by the McElroy Translation Company

800-531-9977

customerservice@mcelroytranslation.com

JAPANESE PATENT OFFICE
 PATENT JOURNAL (A)
 KOKAI PATENT APPLICATION NO. 2001-338838

Int. CL ⁷	H 01 G 4/40 H 01 C 7/00 13/00 H 01 F 27/00 15/00 H 01 G 4/12 H 01 G 4/30 H 03 B 5/04 5/12 H 03 H 5/02 7/06
Filing No.:	P2000-155584
Filing Date:	May 26, 2000
Publication Date:	December 7, 2001
No. of Claims:	12 (Total of 10 pages; OL)
Examination Request:	Not filed

MULTIFUNCTIONAL ELECTRONIC PART, MANUFACTURING METHOD THEREFORE,
 AND VOLTAGE-CONTROLLED OSCILLATOR EQUIPPED THEREWITH

Inventor:	Yoichi Tsuda Sharp Corporation 22-22 Nagaike-cho, Abeno-ku, Osaka-shi, Osaka-fu
Applicant:	000005049 Sharp Corporation 22-22 Nagaike-cho, Abeno-ku, Osaka-shi, Osaka-fu
Agent:	100085501 Shizuo Sano, patent attorney

[There are no amendments to this patent.]

Abstract

Problem

The objective of the present invention is to provide a multifunctional electronic part in which a plurality of mounted constituent elements with different electronic functions constitute a single electronic part, and a voltage-controlled oscillator that enables the board surface area to be made smaller by mounting the multifunctional electronic part.

Means to solve

The multifunctional electronic part, in which a resistor and a capacitor are connected in parallel between mounting conductor electrodes 22, 23, can be constituted by providing a resistor 24 on the surface of an insulated layer except the surfaces on which mounting conductor electrodes 22, 23 are provided in a chip type capacitor 21 provided with mounting conductor electrodes 22, 23 on two opposing surfaces. By connecting such a multifunctional electronic part to the emitter electrode of a transistor for oscillating a voltage-controlled oscillator, for example, the number of elements that constitute the voltage-controlled oscillator can be reduced by one, as compared with the prior art.

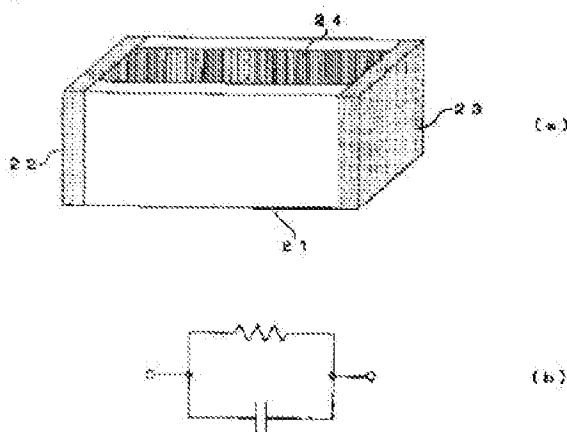

Claims

1. A multifunctional electronic part characterized in that it comprises:
 - a first mounting conductor electrode and a second mounting conductor electrode for electrical connection to the outside, a plurality of first conductor layers electrically and physically connected to only the aforementioned first mounting conductor electrode, a plurality of second conductor layers electrically and physically connected to only the aforementioned second

mounting conductor electrode, a laminated ceramic capacitor formed with insulating layers between and on either side of the aforementioned pluralities of first and second conductor layers so that the aforementioned first conductor layers and the aforementioned second conductor layers appear alternately between the aforementioned insulating layers,

and a resistor that is formed on a surface of [at least one of] the aforementioned insulating layers of said laminated ceramic capacitor except where the aforementioned first and second mounting conductor electrodes are formed, and that is also electrically and physically connected to the aforementioned first and second mounting conductor electrodes.

2. The multifunctional electronic part of Claim 1 characterized in that the form of the aforementioned compound function electronic compound is that of a rectangular parallelepiped, in that the aforementioned first and second mounting conductor electrodes are formed on two opposing surfaces,

and in that the aforementioned resistor is formed on a surface of one of the aforementioned insulating layers on at least one of four surfaces, which excludes the two surfaces on which said first and second mounting conductor electrodes are formed.

3. Manufacturing method for a multifunctional electronic part that has a resistive function and a capacitive function, characterized in that

after first conductor layers and second conductor layers and insulating layers are successively formed so that the aforementioned insulating layers are between and on either side of the aforementioned first and second conductor layers, and

a resistor is formed on an outside surface of [at least one of] the aforementioned insulating layers,

in that a first mounting conductor electrode for electrical connection to the outside is formed to be electrically and physically connected to the aforementioned first conductor layers and the aforementioned resistor,

and in that a second mounting conductor electrode for electrical connection to the outside is formed to be electrically and physically connected to the aforementioned second conductor layers and the aforementioned resistor.

4. The multifunctional electronic part manufacturing method of Claim 3 characterized in that the admittance of the aforementioned compound function electronic compound is measured after the aforementioned multifunctional electronic part is formed,

in that the resistance value of the resistance portion is taken from the real part of the measured admittance value,

and in that the capacitance value of the capacitance portion is taken from the imaginary part of the measured admittance value.

5. A multifunctional electronic part characterized in that it comprises:

a first mounting conductor electrode and a second mounting conductor electrode for electrical connection to the outside, a plurality of first conductor layers electrically and physically connected to only the aforementioned first mounting conductor electrode, a plurality of second conductor layers electrically and physically connected to only the aforementioned second mounting conductor electrode, a laminated ceramic capacitor that is formed with insulating layers between and on either side of the aforementioned pluralities of first and second conductor layers so that the aforementioned first conductor layers and the aforementioned second conductor layers appear alternately between the aforementioned insulating layers,

and an inductor pattern that is formed with a low-resistance conductive material on a surface of [at least one of] the aforementioned insulating layers of said laminated ceramic capacitor except where the aforementioned first and second mounting conductor electrodes are formed, and that is also electrically and physically connected to the aforementioned first and second mounting conductor electrodes.

6. The multifunctional electronic part of Claim 5 characterized in that the form of the aforementioned multifunctional electronic part is that of a rectangular parallelepiped,

in that the aforementioned first and second mounting conductor electrodes are formed on two opposing surfaces,

and in that the aforementioned inductor pattern is formed on a surface of one of the aforementioned insulating layers on at least one of four surfaces which excludes the two surfaces on which said first and second mounting conductor electrodes are formed.

- TO P
2014
2 21224

7. A manufacturing method for a multifunctional electronic part that has a resistive function and a capacitive function, characterized in that

after first conductor layers and second conductor layers and insulating layers are successively formed so that the aforementioned insulating layers are between and on either side the aforementioned first and second conductor layers,

an inductor pattern is formed on an outside surface of [at least one of] the aforementioned insulating layers with a low-resistance conductive material.

in that a first mounting conductor electrode for electrical connection to the outside is formed to be electrically and physically connected to the aforementioned first conductor layers and the aforementioned inductor pattern,

and in that a second mounting conductor electrode for electrical connection to the outside is formed to be electrically and physically connected to the aforementioned second conductor layers and the aforementioned inductor pattern.

8. The multifunctional electronic part manufacturing method of Claim 7 characterized in that the resonance frequency of the aforementioned multifunctional electronic part is measured after the aforementioned multifunctional electronic part is formed.

9. A voltage-controlled oscillator in which the oscillation frequency is changed with a control voltage,

characterized in that it comprises:

a multifunctional electronic part comprising a first mounting conductor electrode and a second mounting conductor electrode for electrical connection to the outside, a plurality of first conductor layers electrically and physically connected to only the aforementioned first mounting conductor electrode, a plurality of second conductor layers electrically and physically connected to only the aforementioned second mounting conductor electrode, a laminated ceramic capacitor formed with insulating layers between and on either side of the aforementioned first and second conductor layers so that the aforementioned first conductor layers and the second conductor layers appear alternately between the aforementioned insulating layers, and a resistor formed on a surface of [at least one of] the aforementioned insulating layers of said laminated ceramic capacitor except where the aforementioned first and second mounting conductor electrodes are formed while also being electrically and physically connected with the aforementioned first and second mounting conductor electrodes.

10. The voltage-controlled oscillator of Claim 9, characterized in that it comprises a resonance circuit composed of an inductor and a voltage-variable capacitor,

and a DC-biased transistor for producing an oscillating output, to the control electrode of which the aforementioned resonance circuit is connected,

and in that a resistor and capacitor, which are connected in parallel with one common end connected to the emitter electrode of the aforementioned oscillation transistor, constitute the aforementioned multifunctional electronic part.

11. A voltage-controlled oscillator in which the oscillation frequency is changed with control voltage,

characterized in that it comprises

a multifunctional electronic part comprising a first mounting conductor electrode and a second mounting conductor electrode for electrical connection to the outside, a plurality of first conductor layers electrically and physically connected with only the aforementioned first mounting conductor electrode, a plurality of second conductor layers electrically and physically connected to only the aforementioned second mounting conductor electrode, a laminated ceramic capacitor formed with insulating layers between and on either side of the aforementioned first and second conductor layers so that the aforementioned first conductor layers and the second conductor layers appear alternately between the aforementioned insulating layers, and an inductor pattern formed with a low-resistance conductive material on a surface of [at least one of] the aforementioned insulating layer of said laminated capacitor except where the aforementioned first

and second mounting conductor electrodes are formed while also being electrically and physically connected to the aforementioned first and second mounting conductor electrodes.

12. The voltage-controlled oscillator of Claim 11 characterized in that it comprises a resonance circuit composed of an inductor and a voltage-variable capacitor, and a DC-biased transistor for producing an oscillating output, to the control electrode of which the aforementioned resonance circuit is connected, and in that the inductor which constitutes the aforementioned resonance circuit and the capacitor, which is used for temperature compensation and is connected in parallel with said inductor constituted by the aforementioned multifunctional electronic part.

Detailed explanation of the invention

[0001]

Technical field of the invention

The present invention relates to a multifunctional electronic part in which electronic constituent elements that have different electrical functions are formed, a manufacturing method therefore, and to a voltage-controlled oscillator equipped therewith.

[0002]

Prior art

The circuit configuration of a voltage-controlled oscillator used in the prior art is shown in Figure 1. The circuit configuration of the voltage-controlled oscillator shown in Figure 1 is the same as that of the voltage-controlled oscillator of the present invention, so that its configuration will be explained briefly immediately and in detail further below. In the voltage-controlled oscillator shown in Figure 1, resonance circuit A comprises a varactor diode D, inductors L1 and L2, and capacitors C1, C2, C3 and C4. Gyrator circuit B comprises an npn transistor T1, capacitors C5, C6 and C7 and resistors R1, R2, R3 and R4. Amplifier circuit C comprises an npn transistor T2, an inductor L3, capacitors C8, C9, C10 and C11, and resistors R1, R2 and R4.

[0003]

In the voltage-controlled oscillator shown in Figure 1, the electronic components that constitute each circuit element are mounted on a board as shown Figure 9. Namely, a 2-transistor, single-package type transistor 1 in which transistors T1, T2 are configured as one electronic component, and chip-type electronic component 3 that constitutes the resistors and capacitors are mounted on substrate 4. The electronic components mounted on substrate 4 are one 2-transistor, single-package type transistor 1, one varactor diode 2, and fifteen other chip type electronic components 3, so that a total of seventeen electronic components are mounted. Moreover,

although not shown, inductors are formed as conductor patterns by printing and firing a conductive paste on substrate 4.

[0004]

The continued demand in recent years to make voltage-controlled oscillators that are constituted with a plurality of elements in this way smaller has been responded to by mounting the plurality of elements more densely. It has also been responded to by reducing the number of components by using multifunctional parts for the mounted constituent elements, as has been proposed for other devices besides voltage-controlled oscillators in Japanese Kokai Patent Application No. Hei 9[1997]-283704.

[0005]

Problems to be solved by the invention

Current high-density mounting technology for small electronic components is nearing its limitations, where the surface area of substrate 4 on which the seventeen electronic components are mounted, as shown in Figure 9, is 5.0 mm x 4.0 mm. Making the size of the mounted electronic components themselves smaller has been considered, but miniaturization of the electronic components is accompanied by manufacturing difficulties. And in terms of circuit performance, the number of mounted constituent elements cannot be further reduced.

[0006]

A multifunctional electronic part with a resistance portion and a capacitance portion, as disclosed in Japanese Kokai Patent No. Hei 9[1997]-283704 has been proposed; it is configured so that the resistance portion and the capacitor portion can be connected in series, but not in parallel as in the circuit configuration of Figure 1. In addition, in order to make the capacitance of the capacitor portion larger, the area of the dielectric film and the electrodes that form the capacitor portion must be increased, so that the area of the semiconductor substrate on which they are formed must also be increased.

[0007]

In addition, voltage-controlled oscillators require a trimming process, in which conductor patterns incorporated into the board must be burned off with a laser, etc., to correct the variation of the inductance of the inductor part and thereby adjust the oscillation frequency.

[0008]

In consideration of such problems, the objective of the present invention is to provide a multifunctional electronic part in which a plurality of mounted constituent elements with different electrical functions are constituted as a single electronic part, a manufacturing method therefore, and a voltage-controlled oscillator, whereby the board surface area can be reduced by mounting the multifunctional electronic part.

[0009]

Means to solve the problems

In order to realize the aforementioned objective, the multifunctional electronic part of Claim 1 is characterized in that it comprises a first mounting conductor electrode and a second mounting conductor electrode for electrical connection to the outside, a plurality of first conductor layers electrically and physically connected to only the aforementioned first mounting conductor electrode, a plurality of second conductor layers electrically and physically connected to only the aforementioned second mounting conductor electrode, a laminated ceramic capacitor formed with an insulating layer between and on either side of the aforementioned first and second conductor layers, so that the aforementioned first conductor layers and the aforementioned second conductor layers appear alternately between the aforementioned insulating layers, and a resistor formed on a surface of [at least one of] the aforementioned insulating layers of said laminated ceramic capacitor except where the aforementioned first and second mounting conductor electrodes are formed, and that is also electrically and physically connected with the aforementioned first and second mounting conductor electrodes.

[0010]

In said multifunctional electronic part, the capacitance portion is formed by forming first and second conductor layers of a conductive material, such as silver- or silver palladium, on either side of each of several insulating layers formed from a glass ceramic material in which an insulating material, such as titanium oxide, barium oxide or lead oxide, has been mixed, so that the insulating layers are between the conductor layers. A first mounting conductor electrode electrically and physically connected to the first conductor layers, and a second mounting conductor electrode electrically and physically connected to the second conductor layers are provided on both sides of the capacitance portion. The surfaces of the capacitance portion, except the surfaces on which the first and second mounting conductor electrodes are connected, are covered with an insulating layer, and a resistor is formed from a resistive material, such as ruthenium oxide, on a surface of [at least one of] the insulating layers to be electrically and physically connected to the first and second mounting conductor electrodes. In this way, a

multifunctional electronic part that has a resistance portion and a capacitance portion connected in parallel between the first and second mounting conductor electrodes is produced.

[0011]

In said multifunctional electronic part of Claim 2, the form of the aforementioned multifunctional electronic part is that of a rectangular parallelepiped, the aforementioned first and second mounting conductor electrodes are formed on two opposing surfaces, and the aforementioned resistor is formed on a surface of one of the aforementioned insulating layers on at least one of four surfaces excluding the two surfaces on which said first and second mounting conductor electrodes are formed.

[0012]

The manufacturing method for a multifunctional electronic part that has a resistive function and a capacitive function of Claim 3 is characterized in that after the aforementioned first and second conductor layers and the aforementioned insulating layer are successively formed so that the insulating layers are formed between and on either side of the first conductor layers and the second conductor layers a resistor is formed on an outside surface of [at least one of] the aforementioned insulating layers the first mounting conductor electrode for electrical connection to the outside is formed to be electrically and physically connected to the aforementioned first conductor layer and the aforementioned resistor, and in that the second mounting conductor electrode for electrical connection to the outside is formed to be electrically and physically connected to the aforementioned second conductor layer and the aforementioned resistor.

[0013]

In this way, after the capacitance part is formed by forming insulating layers and conductor layers as in the conventional technology, a resistor can be formed by forming a pattern by the screen printing, etc., of a resistive material on the surface of the insulating layer. Then by solder-plating with silver paste to connect the mounting conductor electrodes on two opposing surfaces to the sides of the capacitance part where the resistor, which is the resistance part, is formed in this way, the first conductor layers and the resistor are electrically and physically connected to the first mounting conductor electrode, and the second conductor layers and the resistor are electrically and physically connected to the second mounting conductor electrode.

[0014]

As described in Claim 4, the admittance of the aforementioned multifunctional electronic part is measured after the aforementioned multifunctional electronic part is formed, and the

resistance value of the resistance portion is taken from the real part of the measured admittance, and the capacitance value of the capacitance portion is taken from the imaginary part value of the measured admittance.

[0015]

The multifunctional electronic part of Claim 5 is characterized in that it comprises a first mounting conductor electrode and a second mounting conductor electrode for electrical connection to the outside, a plurality of first conductor layers electrically and physically connected to only the aforementioned first mounting conductor electrode, a plurality of second conductor layers electrically and physically connected to only the aforementioned second mounting conductor electrode, a laminated ceramic capacitor that is formed with insulating layers between and on either side of the aforementioned pluralities of first and second conductor layers so that the aforementioned first conductor layers and the aforementioned second conductor layers appear alternately between the aforementioned insulating layers, and an inductor pattern that is formed with a low-resistance conductive material on a surface of [at least one of] the aforementioned insulating layers of said laminated ceramic capacitor except where the aforementioned first and second mounting conductor electrodes are formed, and that is also electrically and physically connected to the aforementioned first and second mounting conductor electrodes.

[0016]

In said multifunctional electronic part, the capacitance portion is formed by forming first and second conductor layers of a conductive material, such as silver or silver palladium, on either side of each of several insulating layers formed from a glass ceramic material in which an insulating material, such as titanium oxide, barium oxide or lead oxide has been mixed so that the insulating layers are between the conductor layers. A first mounting conductor electrode electrically and physically connected with the first conductor layers and a second mounting conductor electrode electrically and physically connected to the second layers are provided on both sides of the capacitance portion. These surfaces of the capacitance portion, except the surfaces on which the first and second mounting conductor electrodes are connected, are covered with an insulating layer, and an inductor pattern is formed from a conductive material, such as silver or silver palladium, on a surface of [at least one of] the insulating layers to be electrically and physically connected to the first and second mounting conductor electrodes. In this way, a multifunctional electronic part that has an inductance portion and a capacitance portion connected in parallel between the first and second mounting conductor electrodes is produced.

[0017]

In said multifunctional electronic part of Claim 6, the form of the aforementioned multifunctional electronic part is that of a rectangular parallelepiped, the aforementioned first and second mounting conductor electrodes are formed on two opposing surfaces, and the aforementioned inductor pattern is formed on a surface of one of the aforementioned insulating layers on at least one of four surfaces excluding the two surfaces on which said first and second mounting conductor electrodes are formed.

[0018]

The manufacturing method for a multifunctional electronic part that has a resistive function and a capacitive function of Claim 7 is characterized in that after the aforementioned first and second conductor layers and the aforementioned insulating layers are successively formed so that the insulating layers are between and on either side of the first conductor layers and the second conductor layers, an inductor pattern is formed on an outside surface of [at least one of] the aforementioned insulating layers with a low-resistance conductive material, a first mounting conductor electrode for electrical connection to the outside is formed to be electrically and physically connected to the aforementioned first conductor layers and the aforementioned inductor pattern, and the second mounting conductor electrode for electrical connection to the outside is formed to be electrically and physically connected to the aforementioned second conductor layers.

[0019]

In this way, after the capacitance part is formed by alternately forming an insulating layer between conductor layers as in the conventional technology, an inductor pattern can be formed by printing the pattern with silver paste by screen printing, etc., the surface of the insulating layer. Then, by solder-plating the silver paste to connect the mounting conductor electrodes on two opposing surfaces to the sides of the capacitance part where the inductor pattern, which is the inductive part, is formed in this way, the first conductor layers and the inductor pattern are electrically and physically connected to the first mounting conductor electrode, and the second conductor layers and the inductor pattern are electrically and physically connected to the second mounting conductor electrode.

[0020]

As of Claim 8, the resonance frequency of the aforementioned multifunctional electronic part can also be measured after the aforementioned multifunctional electronic part is formed.

[0021]

The voltage-controlled oscillator in which the oscillation frequency is changed with a control voltage, of Claim 9 is characterized in that it comprises a multifunctional electronic part comprising a first mounting conductor electrode and a second mounting conductor electrode for electrical connection to the outside, a plurality of first conductor layers electrically and physically connected to only the aforementioned first mounting conductor electrode, a plurality of second conductor layers electrically and physically connected to only the aforementioned second mounting conductor electrode, a laminated ceramic capacitor formed with insulating layers between and on either side of the aforementioned first and second conductor layers such that the aforementioned first conductor layers and the second conductor layers appear alternately between the aforementioned insulating layers, and a resistor formed on a surface of [at least one of] the aforementioned insulating layers of said laminated ceramic capacitor except where the aforementioned first and second mounting conductor electrodes are formed while also being electrically and physically connected to the aforementioned first and second mounting conductor electrodes.

[0022]

The voltage-controlled oscillator of Claim 10 is characterized in that the voltage-controlled oscillator of Claim 9 contains a resonance circuit composed of an inductor and a voltage-variable capacitor and a DC-biased oscillation transistor, to the control electrode of which the aforementioned resonance circuit is connected, and in that a resistor and a capacitor, which are connected in parallel with one common end connected to the emitter electrode of the aforementioned oscillation transistor, constitute the aforementioned multifunctional electronic part.

[0023]

The voltage-controlled oscillator of Claim 11, in which the oscillation frequency is exchanged with control voltage is characterized in that it comprises a multifunctional electronic part comprising a first mounting conductor electrode and a second mounting conductor electrode for electrical connection to the outside, a plurality of first conductor layers electrically and physically connected to only the aforementioned first mounting conductor electrode, a plurality of second conductor layers electrically and physically connected to only the aforementioned second mounting conductor electrode, a laminated ceramic capacitor formed with insulating layers between and on either side the aforementioned first and second conductor layers so that the aforementioned first conductor layers and the second conductor layers appear alternately between the aforementioned insulating layers, and an inductor pattern formed with a low-resistance

conductive material on a surface of [at least one of] the aforementioned insulating layers of said laminated capacitor except where the aforementioned first and second mounting conductor electrodes are formed while also being electrically and physically connected to the aforementioned first and second mounting conductor electrodes.

[0024]

The voltage-controlled oscillator of Claim 12 is characterized in that the voltage-controlled oscillator of Claim 11 contains a resonance circuit composed of an inductor and a voltage-variable capacitor, and a DC-biased oscillation transistor, to the control electrode of which the aforementioned resonance circuit is connected, and in that the inductor, which constitutes the aforementioned resonance circuit and the capacitor, which is used for temperature compensation and is connected in parallel with said inductor are constituted by the aforementioned multifunctional electronic part.

[0025]

Embodiments of the invention

Voltage-controlled oscillator circuit configuration

The voltage-controlled oscillator of the present invention has the circuit configuration shown in Figure 1, like a voltage-controlled oscillator of the prior art. In the voltage-controlled oscillator shown in Figure 1, inductor L1 and capacitor C1, to the common end of which control voltage VT is applied; varactor diode D, the cathode end of which is connected to the other end of inductor L1 and the anode side of which is grounded; capacitor C2, one end of which is connected to the connection node on the cathode side of inductor L1 and variable varactor D; inductor L2 and capacitor C3, which are connected at one end to the other end of capacitor C2 and the other ends of which are grounded; and capacitor C4, one end of which is connected to the connection node of capacitors C2 and C3, are provided, thereby constituting resonance circuit A.

[0026]

In resonance circuit A, in order to supply voltage to control the capacitance of varactor diode D, a low pass filter, formed by inductor L1 and capacitor C1, is used. A parallel resonance circuit is also formed by inductor L2, composed of a $\lambda/4$ strip line resonator, capacitor C3, which is a temperature-compensating element, and varactor diode D. Input of the DC component to a subsequent circuit stage is prevented by capacitor C4. Here, one terminal of capacitor C1 is grounded.

[0027]

Gyrator circuit B comprises npn transistor T1, which is connected to the other end of capacitor C4, which passes the voltage from resonance circuit A of said transistor; to the base capacitor C5, which is connected between the base and emitter of transistor T1; resistors R1 and R2, the common end of which is connected to the base of transistor T1; capacitor C6 and resistor R3, the common end of which is connected to the emitter of transistor T1, with the other terminals grounded; capacitor C7, one end of which is connected to the collector of transistor T1 and the other end of which is grounded; and resistor R4, one end of which is connected to the other end of resistor R2. Here, the other end of resistor R1 is grounded.

[0028]

In addition, amplifier circuit C comprises resistors R1, R2 and R4; npn transistor T2, the base of which is connected to the other end of resistor R2 and the emitter of which is connected to the collector of transistor T1; capacitors C9 and C10 and inductor L3, the common end of which is connected to the collector of transistor T2; and capacitor C11, one end of which is connected to the other end of inductor L3. Here, the other ends of capacitors C9 and C11 are grounded, and the other end of resistor R4 is connected to the other end of inductor L3. In addition, bias voltage VD is applied to the connection node of resistor R4, inductor L3 and capacitor C11.

[0029]

With this constitution, gyrator circuit B stabilizes and outputs a frequency that satisfies the oscillation requirements of resonance circuit A, and the oscillation signal of gyrator circuit B is amplified by amplifier circuit C, which operates as an active circuit for a Colpitts oscillator along with gyrator circuit B. Then the oscillation signal that is amplified in this way is output as a signal with the DC component removed by capacitor C10 from output terminal OUT, which is connected to the other end of capacitor C10. At this time, transistor T1 operates as an oscillation transistor, while transistor T2 operates as an amplification transistor.

[0030]

The voltage-controlled oscillator shown in Figure 1 is used in each of the embodiments explained below. Thus, in each of the embodiments below, it is assumed that the multifunctional electronic part is used with the voltage-controlled oscillator shown in Figure 1.

[0031]

First embodiment

A first embodiment of the present invention will be explained with reference to the attached figures. Figure 2 shows an oblique view and an equivalent circuit diagram that illustrates the configuration of the multifunctional electronic part that has a resistance portion and a capacitance portion provided for the voltage-controlled oscillator of Figure 1. Figure 3 is a cross section of the compound functional electronic component of Figure 2. Figure 4 is a block diagram showing the relationship between the multifunctional electronic part of Figure 2 and an inspection device.

[0032]

The multifunctional electronic part shown in the external oblique view of Figure 2(a) is a multifunctional electronic part in which a resistor and a capacitor are connected in parallel, as shown by the equivalent circuit diagram of Figure 2(b). The multifunctional electronic part shown in Figure 2(a) includes resistor 24, which is formed on one surface on which mounting conductor electrodes 22, 23 are not formed, in rectangular parallelepiped chip-type capacitor 21 that has a laminated ceramic structure provided with mounting conductor electrodes 22, 23 on two opposing faces on two sides.

[0033]

With the multifunctional electronic part of Figure 2(a), chip-type capacitor 21, which is a laminated ceramic capacitor, is formed by conductor layers 31a, the ends at one side surface of which are electrically and physically connected to mounting conductor electrode 22, conductor layers 31b, the ends at one side surface of which are electrically and physically connected to mounting conductor electrode 23, and insulating layers 32, which appear alternately, as in the cross section of Figure 3. Conductor layers 31a, 31b are made of silver, silver palladium, etc., and insulating layers 32 are made of a glass ceramic material in which an insulating material, such as titanium oxide, barium oxide or lead oxide, has been mixed. In this case, the end surfaces of conductor layers 31a opposite the end surfaces connected to mounting conductor electrode 22 are not connected to mounting conductor electrode 23. Likewise, the end surfaces of conductor layers 31b opposite the end surfaces connected to mounting conductor electrode 23 are not connected to mounting conductor electrode 22.

[0034]

Resistor 24 is formed with a resistive material, such as ruthenium oxide, on the top surface of chip-type capacitor 21 formed in this way. Mounting conductor electrodes 22, 23 are formed

with a U shape so that resistor 24 formed on chip-type capacitor 21 can be electrically and physically connected to mounting conductor electrodes 22, 23. Moreover, although it is not shown, a protective film is provided on the surface of the insulating layer 32 on which resistor 24 is formed.

[0035]

With the multifunctional electronic part configured as in Figure 2 and Figure 3, first, a laminated ceramic capacitor on which conductor layers 31a, 31b and insulating layers 32 are laminated is formed by forming a conductive material, such as silver or silver palladium, and a glass ceramic material to be applied by screen-printing or the like. Next, resistor 24 is formed by screen-printing a resistive material on one surface of the laminated ceramic capacitor thus constituted. Then, mounting conductor electrodes 22, 23 are electrically connected with resistor 24 and conductor layers 31a, 31b by connecting mounting conductor electrodes 22, 23 by solder-plating with silver paste on two opposing surfaces of the laminated ceramic capacitor where resistor 24 is formed.

[0036]

The admittance of this multifunctional electronic part can be measured by connecting mounting conductor electrodes 22, 23 of multifunctional electronic part to the leads 42, 43 of measuring device 41, which is an impedance analyzer, which can measure the admittance of the electronic part, as shown in Figure 4. That is, when the admittance $Y = G + jX$ of multifunctional electronic part 40 is measured, its resistance will be $1/G$, and its capacitance will be $X/2\pi f$ (here, f is the frequency of the AC power source that is used when measuring with measuring device 41).

[0037]

The number of components that are mounted in a voltage-controlled oscillator provided with such a multifunctional electronic part, as shown in Figure 5, will be one 2-transistor, single-package type transistor 1, one varactor diode 2, and fourteen other chip-type electronic components 3, including the multifunctional electronic part, mounted on substrate 4, or a total of sixteen. In this case, a mounting spacing of at least 0.2 mm between components is ensured, the same as in the prior art, but the number of components is reduced by one, compared with the prior art, so the size of substrate 4 can be 4.6 mm x 4.0 mm. Thus, the surface area can be reduced by around 8% compared with the size of a conventional substrate.

[0038]

Second embodiment

A second embodiment of the present invention will be explained with reference to the attached figures. Figure 6 shows an oblique view and an equivalent circuit diagram showing the configuration of a multifunctional electronic part that has an inductance portion and a capacitance portion provided for the voltage-controlled oscillator in this embodiment. Figure 7 is a cross section of the multifunctional electronic part of Figure 6. Figure 8 is a block diagram showing the relationship between the multifunctional electronic part of Figure 6 and an inspection device. Here, in Figures 6 and 7, parts with equivalent functions are those for the multifunctional electronic part in Figure 2 and Figure 3 and their detailed explanations are omitted.

[0039]

The multifunctional electronic part shown in the external oblique view of Figure 6(a) is a multifunctional electronic part in which an inductor and a capacitor are connected in parallel, as shown by the equivalent circuit diagram of Figure 6(b), and is a multifunctional electronic part that forms inductor L2 and capacitor C3 of Figure 1. The multifunctional electronic part shown in Figure 6(a) is constituted such that inductor pattern 51 is formed on one surface on which mounting conductor electrodes 22, 23 are not formed, in rectangular parallelepiped chip type capacitor 21 that has a laminated ceramic structure wherein mounting conductor electrodes 22, 23 are provided on two opposing surfaces on two sides.

[0040]

In the multifunctional electronic part of Figure 6(a), chip-type capacitor 21, which is a laminated ceramic capacitor, is formed by conductor layers 31a, the ends at one side surface of which are electrically and physically connected to mounting conductor electrode 22, conductor layers 31b, the end at one side surface of which is electrically and physically connected to mounting conductor electrode 23, and insulating layers 32, which appear alternately, as in the cross section of Figure 7, like the first embodiment.

[0041]

Then inductor pattern 51 is formed with a conductive material, such as silver paste, on the top surface of chip-type capacitor 21 formed in this way. Mounting conductor electrodes 22, 23 are formed with all shape so that inductor pattern 51 formed on chip-type capacitor 21 can be electrically and physically connected to mounting conductor electrodes 22, 23. Moreover, although it is not shown, a protective film is provided on the surface of the insulating layer 32 on which inductor pattern 51 is formed.

[0042]

With the multifunctional electronic part configured as in Figures 6 and 7, like the first embodiment, first, a laminated ceramic capacitor on which conductor layers 31a, 31b and insulating layers 32 are applied is formed by forming a conductive material, such as silver or silver palladium, and a glass ceramic material with screen-printing. Next, inductor pattern 51 is formed by screen-printing a conductive material on one surface of the laminated ceramic capacitor thus constituted. Then, mounting conductor electrodes 22, 23 are electrically connected to inductor pattern 51 and conductor layers 31a, 31b by connecting mounting conductor electrodes 22, 23 by solder-plating the silver paste on two opposing surfaces of the laminated ceramic capacitor on which inductor pattern 51 is formed.

[0043]

The resonance frequency of the multifunctional electronic part is measured by connecting leads 82, 83 from measuring device 81, which is a network analyzer, which can measure the amplitude of the current flowing through the electronic part, to mounting conductor electrodes 22, 23 of multifunctional electronic part 80, as shown in Figure 8. That is, the frequency characteristics relative to the amplitude of the current flowing through multifunctional electronic part 80 are measured, and the frequency at which the current amplitude starts to decrease is detected as the resonance frequency.

[0044]

The multifunctional electronic part for which the resonance frequency is measured in this way can constitute a resonance circuit that has frequency characteristics corresponding to the oscillation frequency used by a voltage-controlled oscillator by connecting to the portion that constitutes inductor L2 and capacitor C3 of resonance circuit A of the voltage-controlled oscillator. Changing the oscillation frequency of the voltage-controlled oscillator can be accommodated by using a multifunctional electronic part with a different resonance frequency, so that the process of trimming the inductor pattern conductor width, as was done in the prior art, can be dispensed with, and the frequency can be easily adjusted. In addition, it will not be necessary to provide inductor patterns on substrates on which other electronic components are mounted, as was done in the prior art, so that the surface area of the substrate can be reduced by the amount of mounting area where the inductor patterns were provided.

[0045]

Here, in the voltage-controlled oscillator shown in Figure 1, both the multifunctional electronic parts explained in the first and second embodiments are mounted. In this way, the surface area of the substrate constituted by the voltage-controlled oscillator can be made even smaller, and the voltage-controlled oscillator can be made even smaller. The multifunctional electronic part of the present invention is also not limited to the forms of the first and second embodiments. For example, the resistor or impedance pattern can be formed on another surface of the insulating layer of the chip-type capacitor, or the resistor or impedance pattern can be formed on a plurality of insulating layer surfaces of the chip type capacitor.

[0046]

Effects of the invention

With the present invention, a multifunctional electronic part in which a capacitance portion and a resistance portion are connected in parallel, or a capacitance portion and an inductance portion are connected in parallel, between first and second mounting conductor electrodes, can be constructed by forming a resistor or inductor pattern on a surface of [at least one of] the insulating layers of a conventional chip-type capacitor. Thus, because it is possible to provide a multifunctional electronic part of approximately the same size as a conventional chip-type capacitor, the surface area of the substrate on which it is mounted can be reduced for various types of circuit configurations.

[0047]

When a multifunctional electronic part in which a capacitance portion and an inductance portion are connected in parallel is used with a voltage-controlled oscillator, because the resonance frequency of the multifunctional electronic part can be measured beforehand, it is not necessary to trim the inductor pattern with a laser, etc., to adjust the frequency, as was done in the prior art, and the oscillation frequency of the voltage-controlled oscillator can be set easily by selecting and providing a compound function electronic element with a resonance frequency according to the oscillation frequency of the voltage-controlled oscillator.

Brief description of the figures

Figure 1 is a circuit diagram showing the configuration of a voltage-controlled oscillator.

Figure 2 is an external oblique view and an equivalent circuit diagram showing the configuration of a multifunctional electronic part in a first embodiment.

Figure 3 is a cross section showing the internal configuration of the multifunctional electronic part of the first embodiment.

Figure 4 shows the relationship between the multifunctional electronic part of the first embodiment and a meter.

Figure 5 is a layout diagram of the electronic components on the substrate surface on which the compound function electronic element of the first embodiment is mounted.

Figure 6 is an external oblique view and an equivalent circuit diagram showing the configuration of a multifunctional electronic part in a second embodiment.

Figure 7 is a cross section showing the internal configuration of the multifunctional electronic part of the second embodiment.

Figure 8 shows the relationship between the multifunctional electronic part of the second embodiment and a meter.

Figure 9 is a layout diagram of the electronic components on the substrate surface on which the electronic components that constitute the conventional voltage-controlled oscillator are mounted.

Explanation of symbols

1	2-transistor single-package type transistor
2	Varactor diode
3	Chip-type electronic component
4	Substrate
21	Chip-type capacitor
22, 23	Mounting conductor electrodes
24	Resistor
31a, 31b	Conductor layers
32	Insulating layers
51	Inductor pattern

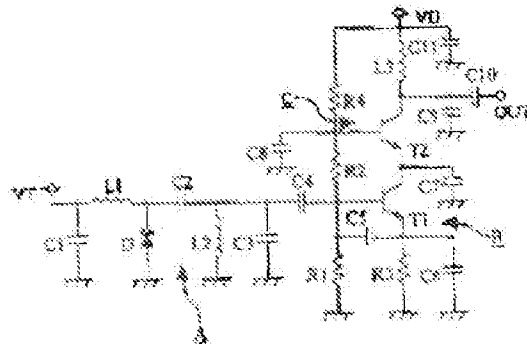

Figure 1

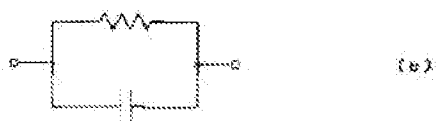
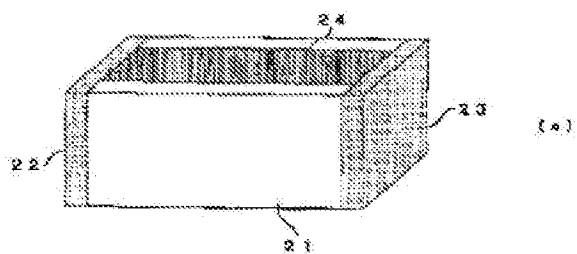

Figure 2

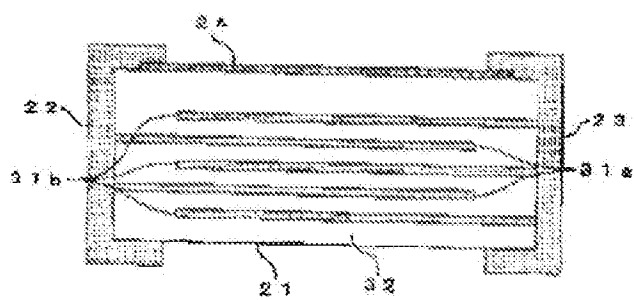

Figure 3

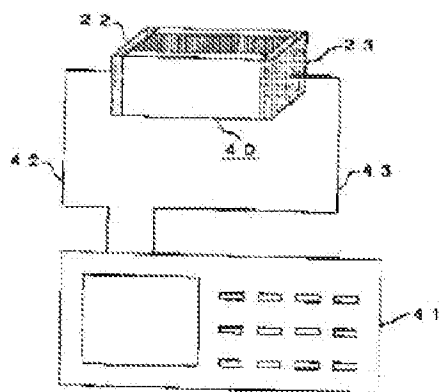

Figure 4

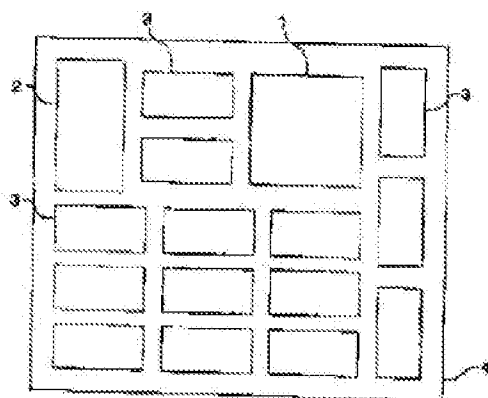

Figure 5

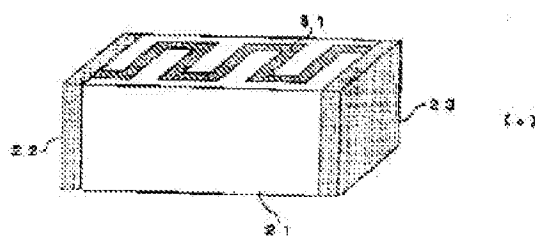

Figure 6

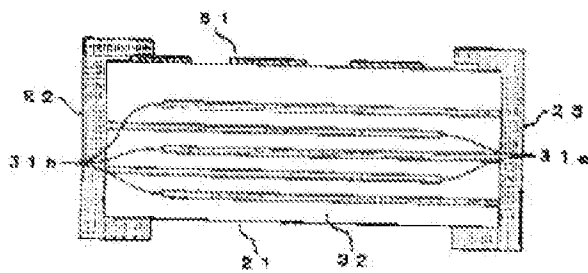

Figure 7

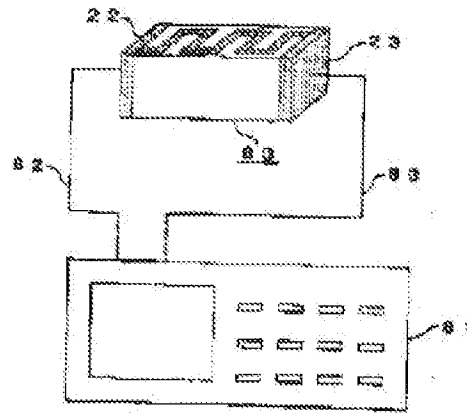

Figure 8

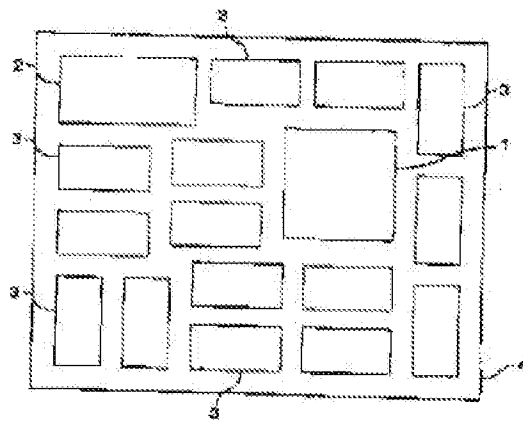

Figure 9